

ADS

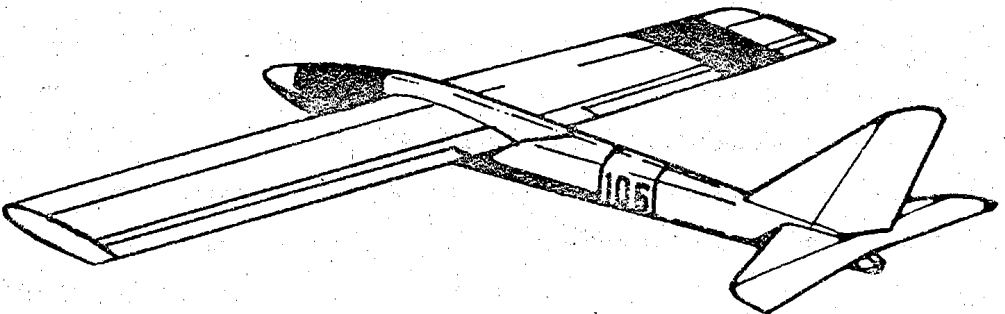

ABERDEEN AND DISTRICT SOARERS

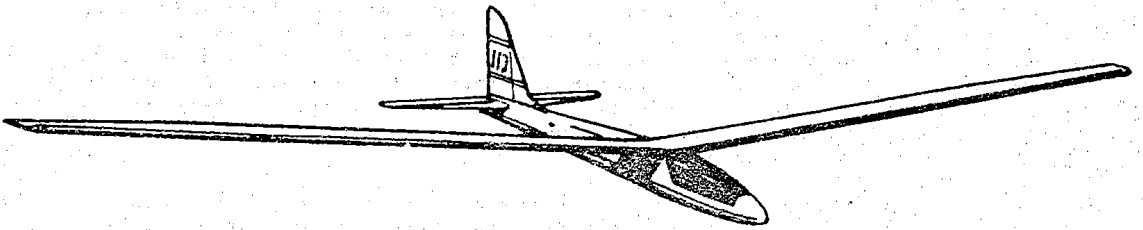

GRAMPIAM GLIDING SITES

1. SLOPE SITES

ELRICK

Access is via A96 Inverurie Road or the A944 Alford Road. Turn off the A96 at Forrit Brae and proceed towards Brimmond Hill or turn off the A944 signed to Blackburn and drive round the western edge of Brimmond. Elrick is situated north of Brimmond and has a distinctive clump of trees on the top. A small track leads to the foot of the hill, a sign directing you to the footpath to the top.

Wind direction 140 - 230 Wind Speed 10 - 20kts

There are plenty of picnic spots available. Lift is limited except when wave exists and things become very smooth. It is an ideal hill for quick trips.

BRIMMOND

Access is as for Elrick. There are three carparks available - one on the north east side one beside Elrick and one on the west opposite Westhill. There are four slopes from which to fly :-

EASTERN RIDGE

Wind direction 070 - 130 Wind speed 10 - 20kts

Care is required to avoid the scatter dishes at the top. Slope lift is limited.

NORTHWEST BOWL

Wind direction 270 - 350 Wind speed 5 - 30kts

This is the most popular slope.

SOUTHWEST RIDGE

Wind direction 200 - 270 Wind speed 5 - 25kts

Slope lift is reasonable, but gorse abounds.

SOUTHERN RIDGE

Wind direction 150 - 230 Wind speed 10 - 20kts

Virtually an untried slope because of Elrick. Please check before use.

DURRIS

Access to the hill is from the A957 Banchory/Stonehaven road via the road to the TV mast. This road is just at the sign 'Fountain Forestry'. Proceed up this road and park at the roadside just 200yds short of the mast. Immediately to the right is a track leading to the northerly mast anchor block. Turn right again just beyond the block climbing the hill at a firebreak between the young trees and left at the top until the top of the slope is reached.

Wind direction 220 - 260

Wind speed 5 - 30kts

The walk is fairly long and steep, but is well worth the climb. The bowl can also be reached from Corfeidly by following a track across the top of the hill.

STRATHFINELLA HILL

Access is from the southern foot of the Cairn o' Mount. Take the road that runs through Glenshugh to Auchenblae. Park opposite the entrance to the Brechin Fishing Area. Walk down the road and across a small ford at the western edge of the loch. Climb the hill immediately in front.

Wind direction 270 -340

Wind speed 5 - 25kts

Note that you have to cross a private area, so please be careful. Lift is good, but the climb is steep.

2. COASTAL SITES

FINDON

Access is off the A92 Stonehaven road at the Findon turn, before reaching Portlethen. Follow the signs to Findon village and on reaching a row of houses running SE to NW at the southern edge of the village, turn right until you reach the Unilever Research Laboratory. Turn left here and drive along until reaching 'Old Mill Road'. Follow this road down a rough track and turn left between the new bungalows. Park next to the 'Cliffs are Dangerous' sign. Now walk about 200yds to the edge of the cliff.

Wind direction 090 -130

Wind speed 5 - 25kts

There is an extremely deep gully at the northern edge of the cliff, no beach at the bottom. However the flying area is fairly shallow allowing a moderate area for landing in front. Not for beginners.

STONEHAVEN

The site is reached from the old south road out of Stonehaven, taking the clifftop footpath from the top of the hill adjacent to the War Memorial. The cliff is on the southern edge of the monument with a large field behind for landing.

Wind direction 090 - 150

Wind speed 5 - 35kts

Parking is limited. If in doubt park at the harbour and walk up the cliff. There is a limited beach at the bottom and the bowl is not very high, so a landing can be achieved at the bottom with care.

ST CYRUS

Turn left at the craft shop at the northern end of the village of St Cyrus. Cross the railway line (disused) and take the road between the church and primary school to the cliff edge. The cliff is about 300/400ft high, virtually sheer with a small winding track down to the 4 mile long beach.

Wind direction 090 -170

Wind speed 5 - 35kts

Care is required because of the 'curl over rotor' at the edge when landing. The area is a nature reserve and is often used by hang gliders. Car parking is limited at the edge, so if in doubt park by the church. A superb 'family' site, with shops, pubs beach etc. Flying is superb.

3. THERMAL SITES

BALMEDIE

Access is from the A92 at the village of Balmedie. Turn to the beach at the White Horse Inn and proceed to the beach car park. Turn right here and park in the overflow carpark at the southern end of the area. The field is directly opposite the carpark area and is recognisable by the football pitch at one end. There is plenty of room in spite of the football pitch. At present power aircraft are not allowed by Gordon District Council in either the field or car park.

SEATON

The area is next to the highrise flats at the Bridge of Don. Golfers practising frequent the area so take care. The area is often flooded due to bad drainage.

4. OTHER SITES

MACKIE ACADEMY

Permission has been granted to fly on the school playing fields - but only when school is out. Power is permitted here. Care is required because of the proximity of the car club site - especially on 27mhz at weekends. ADS members ONLY - please contact G.Philip on 92 64209 before flying.

FOURDON

Flying takes place on the disused Fourdon airfield. A certain amount of fullsize flying still takes place, so it important to check with full size fliers first. Flying takes place on a small area of the western threshold. ADS members ONLY - please contact G.Philip on 92 64209 before flying.

ABERDEEN AND DISTRICT SOARERS

So you are interested in GLIDING. But you ask 'How do I go about it?' 'How do I start?' Hopefully these few lines will help you to untangle some of the myths of Silent Flight.

Basically, there are two types of glider available. First the THERMAL model flown from a flat field and secondly the SLOPE SOARER designed to be flown from a hill. When choosing a first model it is worth considering where you will be flying it. Whilst a THERMAL SOARER can be flown from a slope, some of the smaller SLOPE SOARERS have only a limited endurance when launched from the flat field by means of a tow line.

A good first model would be a 100S class model which has only two controls - rudder and elevator, and are generally quite simple to build. As most of the current designs have been contest proved, the beginner should have every confidence in producing a good flying machine. Launching of these models is usually by a 150m tow line or bungee and the average duration is about ten minutes.

For an out and out SLOPE SOARER, the range available for a first model is even greater and it is possible to start with three channels (rudder, elevator and ailerons), but do try to choose a model of 72" span or greater. The larger the span, within limits, the easier it is to fly and it is certainly easier to see. Flights of over an hour are common with this type of model and in fact the record duration is over 18 hours.

There are of course variations of gliders. There are Open models, Scale models, tail-less models and some with a wingspan of over twenty feet to name but a few. However as this note is being written for the novice, it will be some time before he delves too deeply into these variations.

The attached list is not meant to cover every model available, but each model listed has been built and flown by present or past members of ADS. Their reliability can therefore be assured.

FLAT FIELD SOARERS

Chris Foss 'Centiphase' FG fus F or BU wing	100" span	approx £60
Soar On 'Sunshine' FG fus F or BU wing	100" span	£25-£50
Soar On 'Silhouette' FG fus F or BU wing	142" span	£25-£50
Sailplane International 'Dream' BU fus and wing	88" span	£32
Flair 'Sunrise' BU fus and wing	100" span	£33

FG - Fibre glass
F - Foam
BU - Built up

SLOPE SOARERS

Cambria 'Capstan' BU fus F wing	56" span	£32
Cambria 'Eagle' BU fus and wing	70" span	£30
Mick Reeves 'Snipe' BU fus F wing	75" span	£25
Veron 'Impala' BU fus and wing	56" span	£22

OK, so now you are wondering 'What do I do next?'. Well the answer is contact ADS. Aberdeen District Soarers have been flying as a group for over 8 years and can offer the beginner to gliding the best advice around. The club is represented at almost all major modelling events in Scotland and some in England. Some members have competed in national competitions. Membership costs just £2.00 per year - surely exceptional value for money. Insurance is extra either through the SAA or MAP. An application form is included below.

Club flying sessions are organised most Tuesday evenings in the summer together with Saturday and Sunday. Other sessions are arranged to suit individual members. Flying could be on any of ten slope sites or seven flat field sites for which the club have received permission to fly. The location will of course often be dictated by the wind strength and direction. A quarterly newsletter keeps members informed of what is happening and when together with helpful hints and tips.

ADS MEMBERSHIP APPLICATION

Name.....

Address.....

.....

.....

Do you require SAA membership? (includes insurance) yes/no

If under 16yrs, what is your date of birth?

Complete this form and return to George Whelan, 52, Camperdown Road, Aberdeen.

Committe members for 1986 are :-

- | | |
|---------------|--------------|
| Alan Stewart | tel 722663 |
| Graham Philip | tel 92 64209 |
| George Whelan | tel 636005 |

Any of the above will be pleased to give you more information.

A. D. S. CALENDAR 1987

- 20/01/87 EGM and Bring & Buy Sale, Cammachmore Hotel, 7.30p.m.
- 15/03/87 Cairn O' Mount Xcountry (Cairn Cup) & Fly-in
- 21/04/87 Social Night, Cammachmore Hotel. Beer, sannies and gossip.
- 26/04/87 Tough's Farm Fly-in + Stand off (way, way off) scale comp run concurrently.
- 26/05/87 Fun Evening Comp, Balmedie or Seaton. Soaring at its best. Rules designed to beat the experts
- 31/05/87 Barcs %age Slot, Balmedie. Brian Sherriff Trophy.
- 6,7/06/87 Helicopters at Hazelhead. By Aberdeen Areomodellers
- 20,21/06/87 Bon Accord Display. By Aberdeen Areomodellers
- 23/06/87 Fun Evening Comp. Balmedie or Seaton. Extra points for Slope Soarers.
- 27,28/06/87 Montrose Fly-in
- 26/07/87 Barcs %age Slot, Balmedie. Newsco Trophy.
- 28/07/87 Fun Evening Comp. Balmedie or Seaton. Beginner/Expert team event.
- 1,2/08/87 Scottish Soaring Nationals, Pitreavie. Worth a visit just to watch.
- 9,10/08/87 Fourdon Fly-in. Open to all comers. 100S comp. Concours D'elégance. Barbecue on the Sunday (bring your own steak).
- 23/08/86 Fly-in Banchory Devenick. By Aberdeen Areomodellers
- 30/08/87 Fun Evening Comp. Balmedie, Seaton or Stonehaven. Big prizes.
- 3/87 Fly-in and Scale. Elgin.
- 30/09/87 Fun Comp. Balmedie or Seaton.
- 1/87 Taylor Trophy. Elgin. On of the better day's out.
- 1/87 Social night and dance 8pm Cammachmore Hotel.
- 1/87 Cairn O' Mount Fly for fun. Grampian Cup. Simple comp.
- 1/87 AGM 7.30p.m. Venue to be announced.

IS OF INTEREST

- 30/09/87 Soaring Comp, Elgin
- 87 %age Slot, Glenraig
- 37 100S, Glenraig
- 30/09/87 Radioglide
- 37 %age Slot, Tain
- 37 Soaring Comp, Elgin
- 17 Xcountry, East Lomond
- 17 %age Slot, Glenraig
- 13/09/87 Xcountry, East Lomond

